

Fire Test Report

ANSI/API Standard 607, Fifth Edition, June 2005

ISO 10497-5:2004

Performed for

Guide Valve Supply Ltd. (GVS)

www.gvs-vci.com



2 inch Class 2500 B1 Ball Valve
Model: B1-2500-PS-RTJ-L

Project Number: 210069
October 2010

Performed by

YARMOUTH RESEARCH AND TECHNOLOGY, LLC

434 Walnut Hill Road
North Yarmouth, ME 04097 USA
(207) 829-5359

info@yarmouthresearch.com
www.yarmouthresearch.com

Yarmouth Research and Technology, LLC

Customer: GVS

Date: 10/30/2010

Specification: ANSI/API Standard 607, 6th Edition, 2010
ISO 10497:2010

Product Description: 2 inch Class 2500 Trunnion Ball Valve

Project Number: PN210069

Comments: Model: B1-2500-PS-RTJ-L

Yarmouth Engineer: Matthew J. Wasielewski, P.E.

Equipment Confirmed to be in Calibration to NIST Standards: Yes

Burn and Cool Down Test

Burn Start Time:	12:45:00	
Average Pressure During Burn:	4642	psig
Seat Leak Rate During Burn:	0	ml/min
Allowable Seat Leak Rate:	800	ml/min
External Leak Rate During Burn/Cool Down:	6	ml/min
Allowable External Leak Rate:	200	ml/min
Amount of Time of Avg. Cal. Blocks > 650 deg. C:	20.8	minutes
Were Test Conditions Within Compliance?	Yes	
Were the Valve Leakages Below the Allowables?	Yes	

Operational Test

Did Valve Unseat and Open Fully?:	Yes	
Average Pressure During Test:	4591	psig
External Leak Rate After Operating:	16	ml/min
Allowable External Leak Rate:	50	ml/min
Was the Leakage Below the Allowable?	Yes	

Valve Pass or Fail the Test Standard?	PASS
--	-------------

Witnesses

Matthew J. Wasielewski

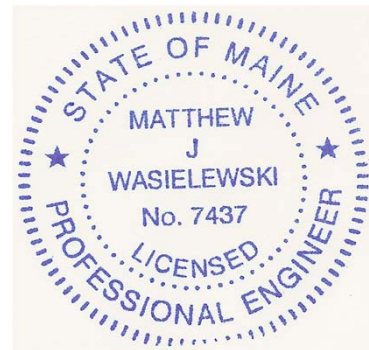

ALL DIMENSIONS IN INCHES

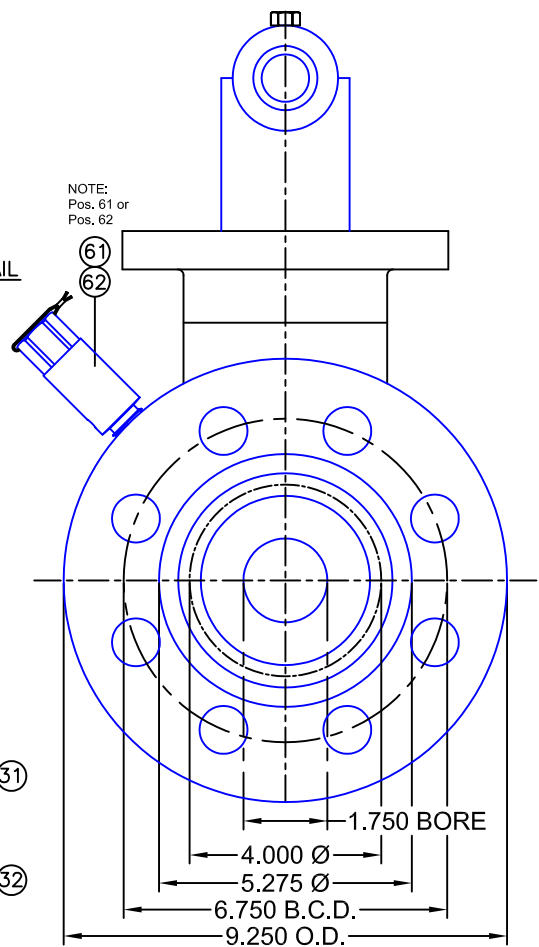
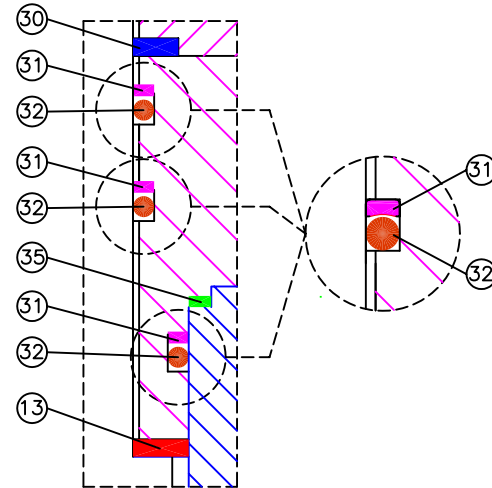
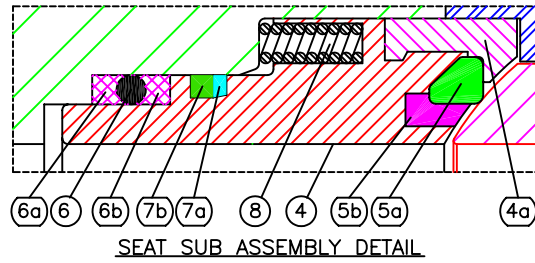
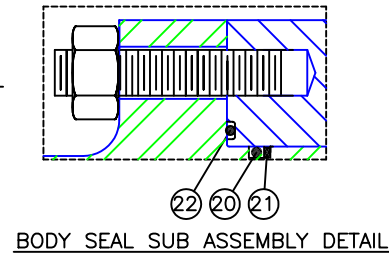
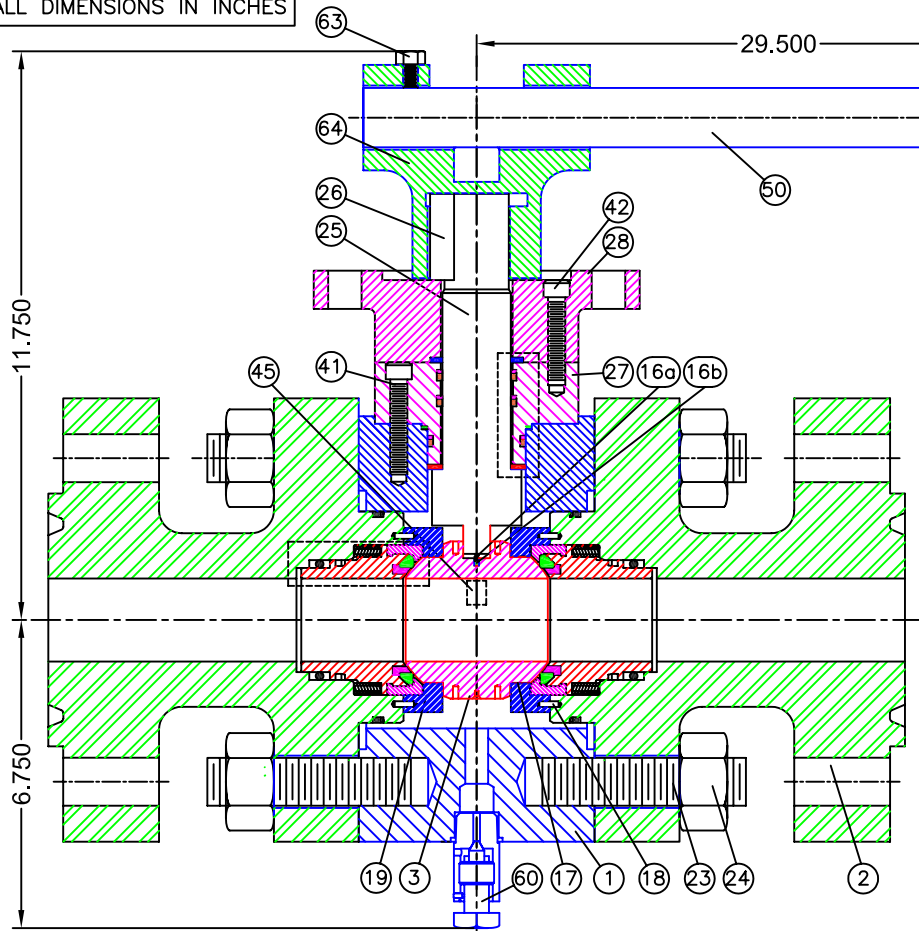

NOTE:
Pos. 61 or
Pos. 62

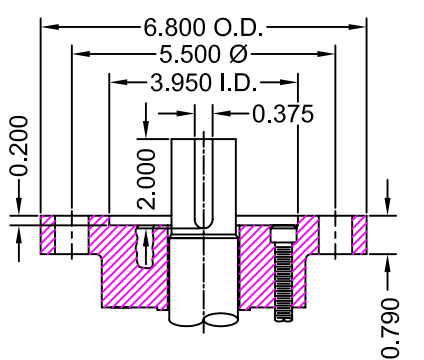
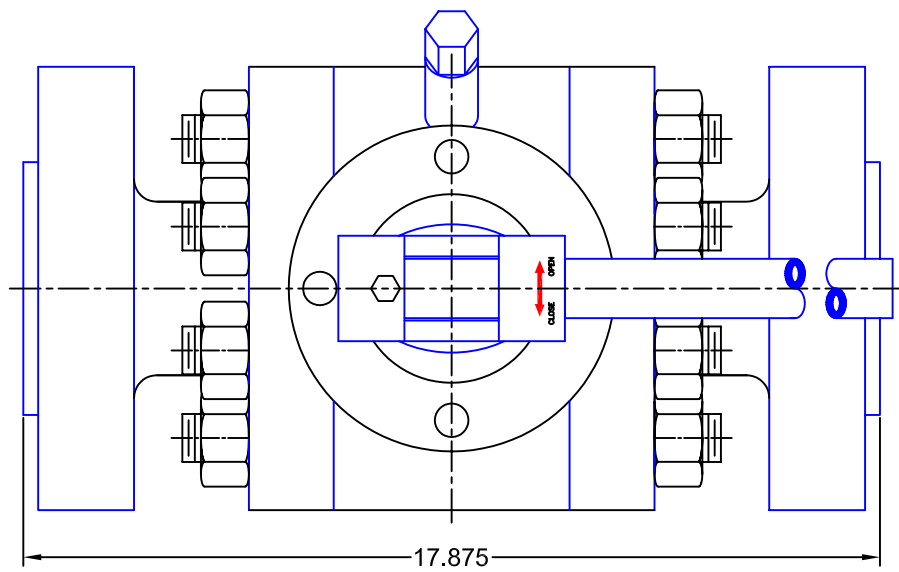

BALL VALVE MAIN CHARACTERISTICS:-
 DOUBLE BLOCK & BLEED (CLOSED & OPEN POSITION).
 DOUBLE PISTON EFFECT SEAT FEATURE
 TRIPLE STEM SEALING DESIGN.
 ANTISTATIC DEVICES.
 FIRE SAFE DESIGN
 WEIGHT OF VALVE ASSEMBLY 258#
VALVES ACCORDING TO:-
 API 6D 23 Ed.
 CSA Z245.15 2005
 NACE MR0175/ISO15156-2003

NOTE:
 This drawing to be read in conjunction with drawing No. GVS-NP-10-0205 Rev 01 Bill of Materials - 'TypeLT'

01	General Revisions	TB	JG	AZ	MK	AJB	24-Aug-10
Rev.	Description	By	Chk'd	Apprd	Apprd	Apprd	Date
Drawing Title							
2" Model # B1-2500-RTJ-L Valve Assembly Drawing							
GVS LTD. <small>Brampton, Ontario, Canada</small>	Drawn By	TB	24-Aug-10	Drawing No.			
	Checked By	JG		GVS-NP-10-0204			
	Approved By	AZ					
	Approved By	MK					
Do Not Scale				Sheet No.		1 of 2	

Valve design licensed from Nuovo Pignone Bari Italy
 This document is the property of GVS LTD.
 All rights to content are reserved by law.

TOP MOUNTING FLANGE DIMENSIONS

YARMOUTH RESEARCH AND TECHNOLOGY

Fire Test Information Sheet

Valve Manufacturer's Name:	GUIDE VALVE SUPPLY LIMITED
Valve Manufacturer's Address:	14 Melanie Drive, Unit 9-10-11 Brampton, Ontario Canada L6T 4 L3
Did valve meet all required hydrostatic, leakage and other production pressure tests?	YES
Valve Product Code:	MODEL B1-2500-PS-RTJ-L
Valve Description Size: Pressure Rating: Pressure Rating at 100F: Type: Weight: Reduced or Full Bore: Body/Bonnet Material: Trim Material: Seat Material: Stem / Body Seal Material: Bolting Material: Is valve considered "Soft-Seated"?	2" 2500 # ANSI CLASS RATING, 6170 psig, type : Trunnion mounted ball valve;weight 258 lbs;full ported;body and bonnet of ASTM A 350 LF2 Cl 1 NACE:Trim: Ball of ASTM A 350 LF2 Cl 1 + ENP;Seats ASTM A 350 LF2 Cl 1,seat HNBR ,VITON PEEK.Stem seal is HNBR and Grahoil,body stud of ASTM A 320 L7M, Nut ASTM A 194 7M Soft seated held in metal housing.
Valve Markings Nameplate Information: Casting Markings:	Manufactured by GVS Ltd. Forgung of body is stamped with GVS Ltd.
Assembly Drawing Number / Revision / Date of Issue:	GVS-NP-09-0201 Rev 06 dated 19 th of March 2010
Assembly Drawing sent to Yarmouth:	YES
If valve is fitted with gearbox, state gearbox manufacturer, model number and mechanical advantage:	Not applicable the 2" valve was supplied with lever handle
If valve is non-symmetric, state direction of flow for test:	N/A
For double-seated valves, state maximum allowable cavity pressure:	
Manufacturer's Contact Name /Date:	

Temperature verses Time Chart

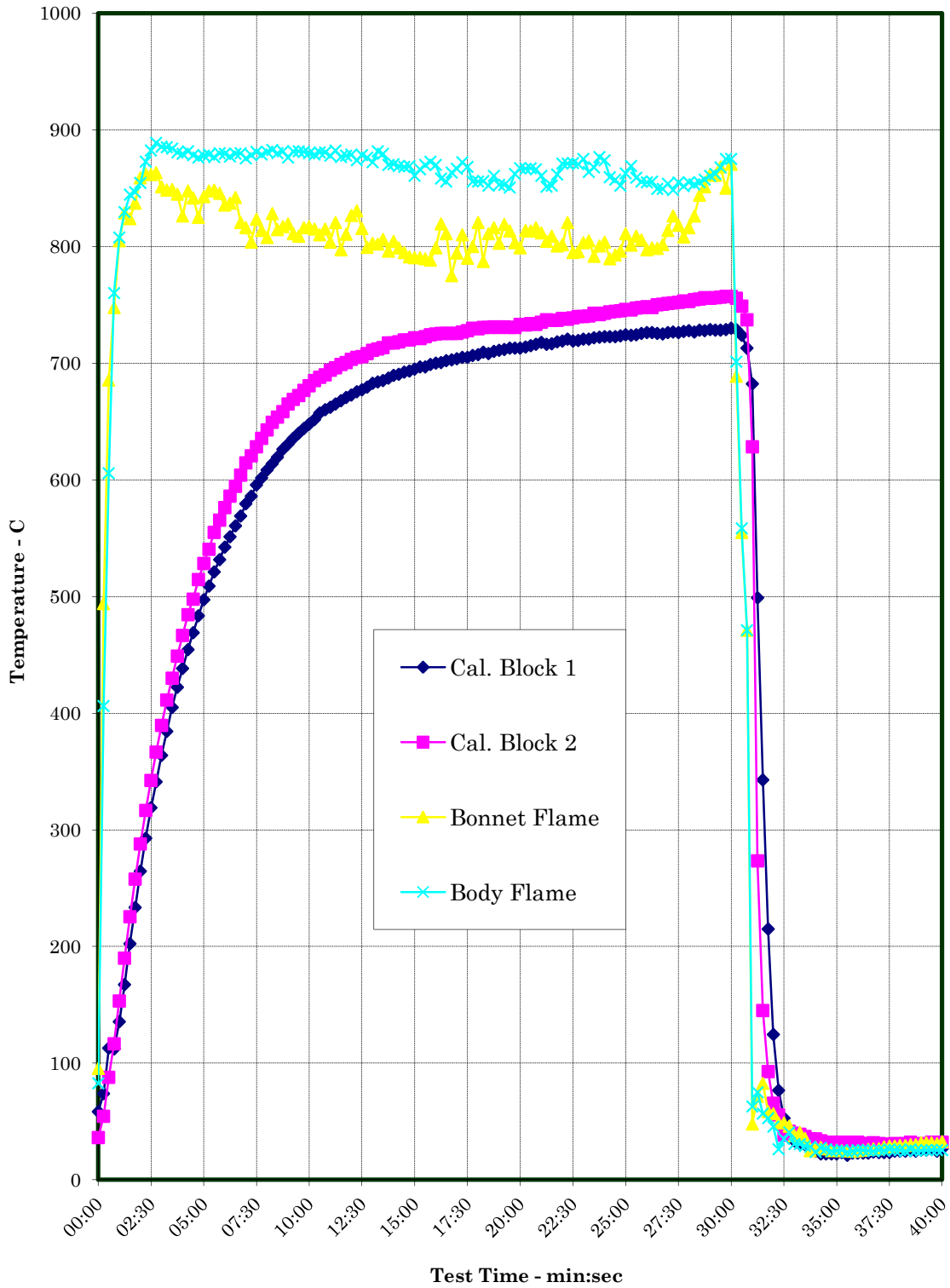

Pressure verses Time Chart

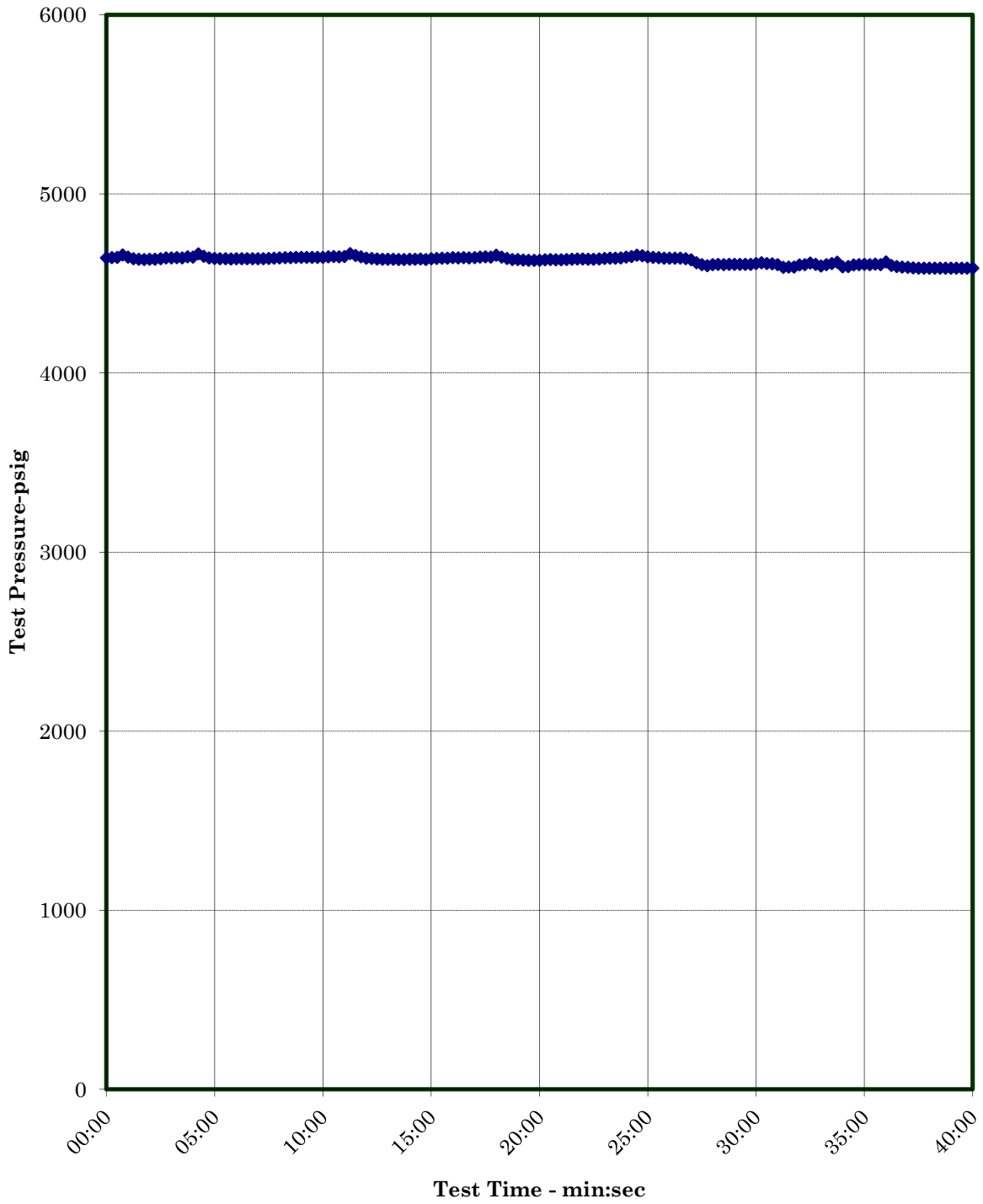



Valve During Burn

Yarmouth Research and Technology, LLC



Valve During Burn

Yarmouth Research and Technology, LLC

Fire Test Information

Customer: GVS

Date: 10/30/2010

Product Code: 2 inch Class 2500 Trunnion Ball Valve

Project Number: PN210069

Fire Test Raw Data

Time	Pressure (psig)	Water Volume (mls)	Cal. Block 1 Temp-C	Cal. Block 2 Temp-C	Avg. Cal Block Temp-C	Bonnet Flame Temp-C	Body Flame Temp-C	Average Flame Temp-C
12:45:00	4643	44501	58	36	47	96	83	89
12:45:15	4644	44464	74	54	64	494	406	450
12:45:30	4645	44242	113	88	100	686	606	646
12:45:45	4659	44393	112	117	114	748	760	754
12:46:00	4646	44486	136	153	144	805	808	806
12:46:15	4638	44464	167	190	179	829	829	829
12:46:30	4634	44676	202	226	214	824	844	834
12:46:45	4633	44578	233	258	246	837	847	842
12:47:00	4634	44694	264	288	276	859	854	857
12:47:15	4635	44674	293	317	305	862	873	868
12:47:30	4638	44274	319	342	331	862	882	872
12:47:45	4642	44604	341	367	354	863	889	876
12:48:00	4643	44246	364	389	377	851	886	868
12:48:15	4644	44444	384	411	398	848	885	867
12:48:30	4643	44640	405	430	418	849	884	866
12:48:45	4649	44628	422	449	436	845	881	863
12:49:00	4647	44622	438	467	453	826	879	853
12:49:15	4665	44497	454	484	469	848	882	865
12:49:30	4652	44543	469	498	483	842	878	860
12:49:45	4642	44476	483	514	499	825	876	851
12:50:00	4639	44335	497	528	513	843	878	860
12:50:15	4638	44493	509	541	525	848	879	863
12:50:30	4638	44504	521	555	538	848	877	863
12:50:45	4637	44492	532	566	549	846	880	863
12:51:00	4637	44436	542	576	559	836	879	858
12:51:15	4637	44385	551	586	569	837	877	857
12:51:30	4637	44455	561	594	578	842	879	861
12:51:45	4638	44428	569	604	586	821	880	850
12:52:00	4638	44412	579	614	597	816	876	846
12:52:15	4638	44416	586	621	603	804	878	841
12:52:30	4639	44443	596	628	612	823	881	852
12:52:45	4640	44425	602	636	619	814	879	846
12:53:00	4643	44433	608	643	626	808	881	844

Yarmouth Research and Technology, LLC

Fire Test Data - continued

12:53:15	4644	44434	614	649	632	828	883	856
12:53:30	4644	44433	619	654	637	814	880	847
12:53:45	4645	44438	626	658	642	817	882	849
12:54:00	4646	44435	631	665	648	819	876	848
12:54:15	4646	44437	636	669	652	811	882	846
12:54:30	4645	44437	640	672	656	809	882	845
12:54:45	4645	44435	644	677	660	816	881	849
12:55:00	4645	44418	648	681	664	817	880	849
12:55:15	4649	44412	652	685	668	815	879	847
12:55:30	4650	44458	657	688	673	810	881	845
12:55:45	4648	44390	660	690	675	815	881	848
12:56:00	4650	44446	662	694	678	804	878	841
12:56:15	4667	44428	665	696	681	821	882	851
12:56:30	4656	44337	668	699	683	797	877	837
12:56:45	4649	44498	671	701	686	811	878	844
12:57:00	4641	44496	673	703	688	827	879	853
12:57:15	4639	44548	676	705	690	831	874	852
12:57:30	4636	44467	677	706	691	816	878	847
12:57:45	4635	44248	679	708	694	799	876	838
12:58:00	4636	44473	683	711	697	803	872	838
12:58:15	4635	44344	684	712	698	802	882	842
12:58:30	4634	44195	685	713	699	806	879	843
12:58:45	4633	44672	687	717	702	796	870	833
12:59:00	4635	44251	689	717	703	804	871	838
12:59:15	4635	44460	691	718	704	799	869	834
12:59:30	4636	44281	692	720	706	795	868	832
12:59:45	4633	44528	693	720	707	791	869	830
13:00:00	4637	44288	695	722	708	791	861	826
13:00:15	4639	44475	697	721	709	791	866	828
13:00:30	4640	44371	697	723	710	789	870	830
13:00:45	4641	44411	699	724	712	788	873	831
13:01:00	4644	44445	700	725	713	799	870	834
13:01:15	4642	44462	701	726	713	819	858	839
13:01:30	4644	44382	702	726	714	811	856	833
13:01:45	4643	44451	703	726	714	775	863	819
13:02:00	4644	44380	704	726	715	794	867	831
13:02:15	4647	44413	705	727	716	810	872	841
13:02:30	4648	44412	705	728	716	790	868	829
13:02:45	4647	44392	707	730	718	800	856	828
13:03:00	4658	44411	707	729	718	821	856	838
13:03:15	4646	44371	709	731	720	787	856	822
13:03:30	4640	44385	708	731	719	811	852	832
13:03:45	4634	44387	710	731	721	816	861	838

Yarmouth Research and Technology, LLC

Fire Test Data - continued

13:04:00	4633	44389	711	731	721	803	853	828
13:04:15	4631	44371	712	731	721	819	853	836
13:04:30	4629	44374	713	731	722	813	851	832
13:04:45	4629	44373	713	731	722	803	862	833
13:05:00	4629	44384	713	733	723	799	867	833
13:05:15	4631	44390	714	733	723	814	867	840
13:05:30	4633	44380	715	734	724	813	867	840
13:05:45	4632	44390	716	733	725	816	866	841
13:06:00	4632	44401	718	735	726	812	861	836
13:06:15	4633	44380	716	737	727	804	851	828
13:06:30	4635	44381	717	737	727	809	852	831
13:06:45	4636	44372	718	737	728	801	862	831
13:07:00	4636	44390	719	738	729	802	871	836
13:07:15	4635	44395	721	738	729	821	871	846
13:07:30	4635	44370	719	739	729	795	872	833
13:07:45	4637	44382	719	740	730	796	871	833
13:08:00	4639	44380	721	740	730	803	875	839
13:08:15	4641	44375	721	741	731	805	864	834
13:08:30	4640	44384	722	743	732	792	868	830
13:08:45	4643	44381	722	742	732	801	877	839
13:09:00	4647	44364	723	743	733	804	874	839
13:09:15	4650	44380	723	744	733	789	859	824
13:09:30	4657	44376	723	744	734	793	857	825
13:09:45	4654	44378	723	745	734	796	852	824
13:10:00	4648	44378	724	746	735	811	863	837
13:10:15	4645	44383	724	746	735	801	869	835
13:10:30	4643	44371	724	747	736	809	859	834
13:10:45	4640	44375	726	748	737	806	856	831
13:11:00	4641	44372	726	748	737	797	855	826
13:11:15	4640	44380	726	748	737	799	856	827
13:11:30	4641	44379	726	750	738	798	849	824
13:11:45	4638	44385	725	751	738	802	849	826
13:12:00	4631	44366	726	751	739	814	854	834
13:12:15	4616	44373	727	752	739	826	848	837
13:12:30	4605	44381	726	752	739	818	855	837
13:12:45	4599	44379	727	753	740	808	852	830
13:13:00	4605	44374	728	753	740	816	855	836
13:13:15	4606	44389	727	754	741	826	853	840
13:13:30	4605	44381	728	755	742	844	855	849
13:13:45	4606	44394	728	756	742	851	857	854
13:14:00	4606	44397	729	756	742	862	861	861
13:14:15	4606	44352	728	756	742	861	862	862
13:14:30	4606	44364	728	757	743	868	868	868

Yarmouth Research and Technology, LLC

Fire Test Data - continued

13:14:45	4607	44366	729	757	743	850	875	863
13:15:00	4610	44370	730	757	744	871	875	873
13:15:15	4615	44378	729	756	742	689	701	695
13:15:30	4610	44373	724	749	736	555	558	557
13:15:45	4609	44376	713	737	725	471	471	471
13:16:00	4604	44366	682	628	655	48	63	55
13:16:15	4590	44365	499	273	386	72	75	73
13:16:30	4591	44353	343	145	244	83	57	70
13:16:45	4591	44352	215	93	154	58	53	56
13:17:00	4602	44346	124	66	95	57	46	51
13:17:15	4604	44324	77	56	66	49	26	38
13:17:30	4614	44342	53	38	46	49	35	42
13:17:45	4606	44299	40	42	41	46	41	43
13:18:00	4596	44296	33	40	37	38	31	34
13:18:15	4605	44329	31	39	35	41	31	36
13:18:30	4611	44317	30	37	34	36	29	32
13:18:45	4618	44283	29	35	32	25	28	27
13:19:00	4593	44292	24	35	30	28	24	26
13:19:15	4595	44279	22	33	28	28	27	28
13:19:30	4603	44294	22	32	27	27	26	26
13:19:45	4605	44295	22	32	27	25	24	25
13:20:00	4606	44292	22	32	27	26	25	25
13:20:15	4605	44297	23	32	28	25	26	25
13:20:30	4608	44293	21	32	27	25	24	24
13:20:45	4604	44277	23	31	27	24	24	24
13:21:00	4620	44278	23	32	28	25	26	25
13:21:15	4601	44273	23	31	27	26	26	26
13:21:30	4595	44296	23	31	27	26	25	26
13:21:45	4592	44285	24	32	28	27	24	26
13:22:00	4589	44265	23	31	27	27	26	26
13:22:15	4587	44282	23	30	27	28	25	27
13:22:30	4585	44283	23	31	27	29	26	28
13:22:45	4585	44285	24	31	28	29	26	27
13:23:00	4586	44273	24	31	28	29	26	28
13:23:15	4586	44274	24	31	28	29	24	27
13:23:30	4585	44269	25	32	29	30	26	28
13:23:45	4585	44267	24	31	28	30	25	28
13:24:00	4585	44278	26	30	28	32	25	28
13:24:15	4585	44278	26	31	28	32	26	29
13:24:30	4585	44275	26	32	29	32	26	29
13:24:45	4585	44278	24	31	28	31	26	28
13:25:00	4584	44273	27	32	29	33	26	29

Yarmouth Research and Technology, LLC

Leakage Summary for Burn and Cool Down Periods

All pressure transducers and thermocouples are in calibration per YRT's QA program.

Seat leakages were collected manually. External leakage was collected electronically.

Total Through Seat Leakage Collected Over 30 Minute Duration:	0	mls
Average Leak Rate Over 30 Minute Duration:	0	ml/min
Allowable Leak Rate:	800	ml/min
Total Through Seat Leakage Collected Over 10 Minute Cool Down:	0	mls
Total Water Volume Lost Over 40 Minute Burn and Cool Down:	228	mls
Water Collected in System Relief Valve:	0	mls
Calculated External Leakage During 40 Minute Duration:	228	mls
Average Leak Rate Over 40 Minute Duration:	6	ml/min
Allowable Leak Rate:	200	ml/min

Were the Valve Leakages Below the Allowables?	Yes
--	------------

Yarmouth Research and Technology, LLC

Summary of Test Parameters During Burn and Cool Down Periods

Amount of Time Pressure Dropped Below 50%:	0.0	minutes
Maximum Allowable Low Pressure Time:	2.0	minutes
Maximum Pressure During Burn/Cool Down:	4667.0	psig
Average Pressure During Burn/Cool Down:	4627.8	psig
Minimum Pressure During Burn/Cool Down:	4584.5	psig
Amount of Time of Avg. Cal Block > 650 deg.C:	20.8	minutes
Minimum Allowable Time at Temperature:	15.0	minutes
Maximum Avg Cal Block Temperature:	730.0	deg. C
Average Cal Block Temperature:	494.1	deg. C
Lowest Avg Cal. Block Temperature:	21.1	deg. C
Maximum Body Flame Temperature During Burn:	888.9	deg. C
Average Body Flame Temperature During Burn:	857.1	deg. C
Maximum Bonnet Flame Temperature During Burn:	870.6	deg. C
Average Bonnet Flame Temperature During Burn:	809.3	deg. C
Average of Both Flame Temperatures During Burn:	833.2	deg. C

Note

Were Test Conditions Within Compliance?	Yes
--	------------

Yarmouth Research and Technology, LLC

Post-Burn Seat Test Information

Customer: GVS

Date: 10/30/2010

Product Code: 2 inch Class 2500 Trunion Ball Valve

Project Number: PN210069

Test Data

This test not required for this pressure valve.

Yarmouth Research and Technology, LLC

Operational Test Information

Customer: GVS

Date: 10/30/2010

Product Code: 2 inch Class 2500 Trunnion Ball Valve

Project Number: PN210069

Test Data

Time	Pressure (psig)	Cal Block Temp - C
13:27:01	4596	32
13:27:16	4591	32
13:27:31	4586	32
13:27:46	4583	32
13:28:01	4581	32
13:28:16	4583	32
13:28:31	4585	31
13:28:46	4587	33
13:29:01	4589	33
13:29:16	4591	32
13:29:31	4591	33
13:29:46	4592	33
13:30:01	4593	34
13:30:16	4593	33
13:30:31	4594	33
13:30:46	4595	34
13:31:01	4596	33
13:31:16	4597	34
13:31:31	4598	34
13:31:46	4598	34
13:32:01	4601	34

Leakages were collected manually.

Total External Leakage Collected Over 5 Minute Duration:	80	mls
Average Leak Rate Over 5 Minute Duration:	16	ml/min
Allowable Leak Rate:	50	ml/min

Was the Valve Leakage Below the Allowable?	Yes
--	-----